



Before You Start:

Please familiarize yourself with all the steps before beginning assembly.

Compatibility Info:

This Door System is designed to work with other Seizmik branded Accessories for the Full Size Polaris Ranger as well as OEM Polaris branded hard tops. Please note Seizmik cannot guarantee fitment with other branded aftermarket products. Please research installation details thoroughly on our products & others when trying to combine different branded accessories.

Seizmik makes Windshields, Mirrors, Cab Systems, Light Bars, Storage Boxes, Hood Racks, and other great accessories for UTV's to maximize the vehicles usefulness. To help you do what you do better.

Installation information:

- Approximate installation time: 1 – ½ hours
- This product is easiest to install with: 2 people

If you have any questions, comments, need assistance, or are missing parts, please call 1-866-838-3366 xt.110 between 9:00AM and 5:00PM EST. Or email us at support@seizmik.com. Visit www.seizmik.com for more information on our products.

Ranger Doors Parts List

Item	Description	Qty.	Item	Description	Qty.
1	Upper Door Frame	2	10	Door Handle	2
2	Lower Door Frame	2	11	Spacers	4
3	Rear Hangar Frame	2	12	Hook Connector	2
4	Upper Hangar Frame	2	13	Rear Hangar Mtg. Brkt.	2
5	Lower Hangar Frame	2	14	Pan Head M6 x 25	14
6	Lower Hangar Mount	2	15	Pan Head M6 x 30	6
7	Upper Hangar Mtg. Plate	2	16	Pan Head M6 x 20	2
8	Bar Clamp	2	17	1/4 - 20 x 2.5 Bolt & Nut	2
9	End Plug	4	18	1.4" Washer	8

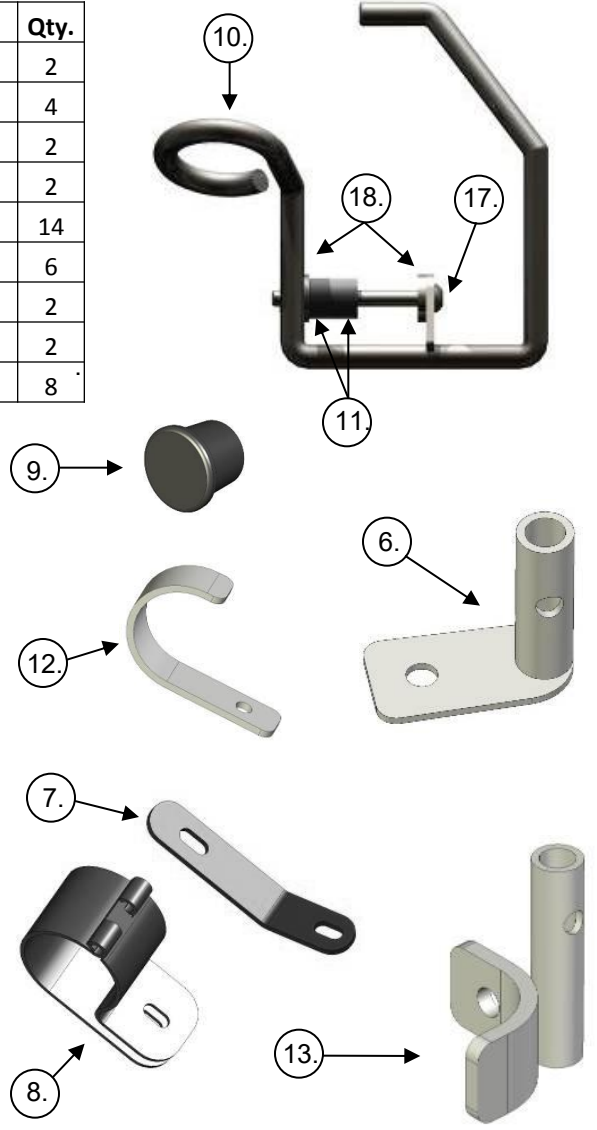
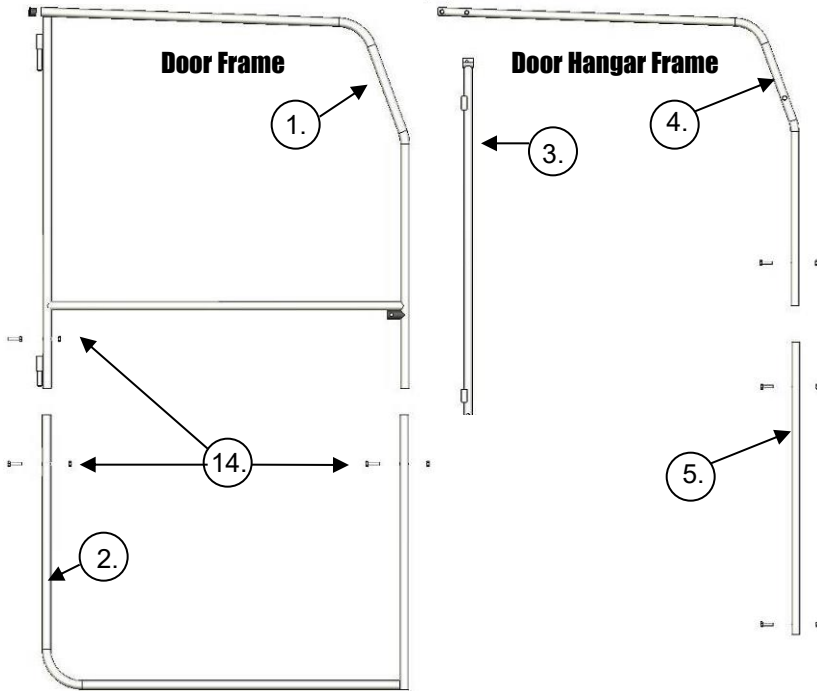

Textiles

- 1. Upper Passenger Door
- 2. Lower Passenger Door
- 3. Upper Driver Door
- 4. Lower Driver Door
- 5. Passenger Side Panel
- 6. Driver Side Panel



Bolt Index

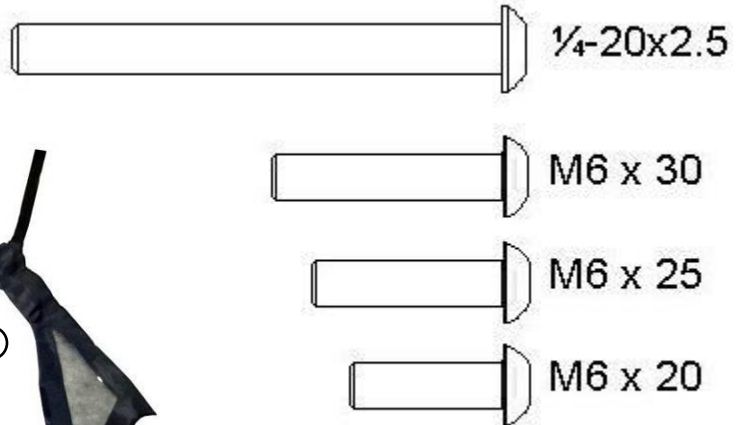

For item part numbers refer to the appendix at the back of these instructions.

Door Hangar Frame Assembly

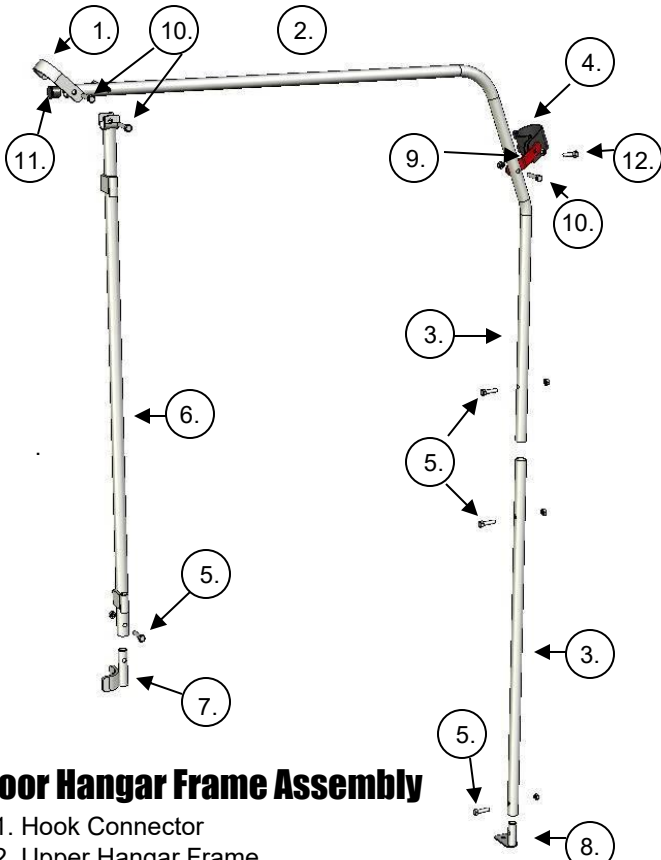

Door Hangar Frame Assembly

- | | |
|--------------------------|---------------------------|
| 1. Hook Connector | 8. Lower Hangar Mount |
| 2. Upper Hangar Frame | 9. Upper Hangar Mt. Plate |
| 3. Lower Hangar Frame | 10. Pan Head M6 x 30 |
| 4. Clamp | 11. End Plug |
| 5. Pan Head M6 x 25 | 12. Pan Head M6 x 20 |
| 6. Rear Hangar Frame | |
| 7. Rear Hangar Mtg. Brkt | |

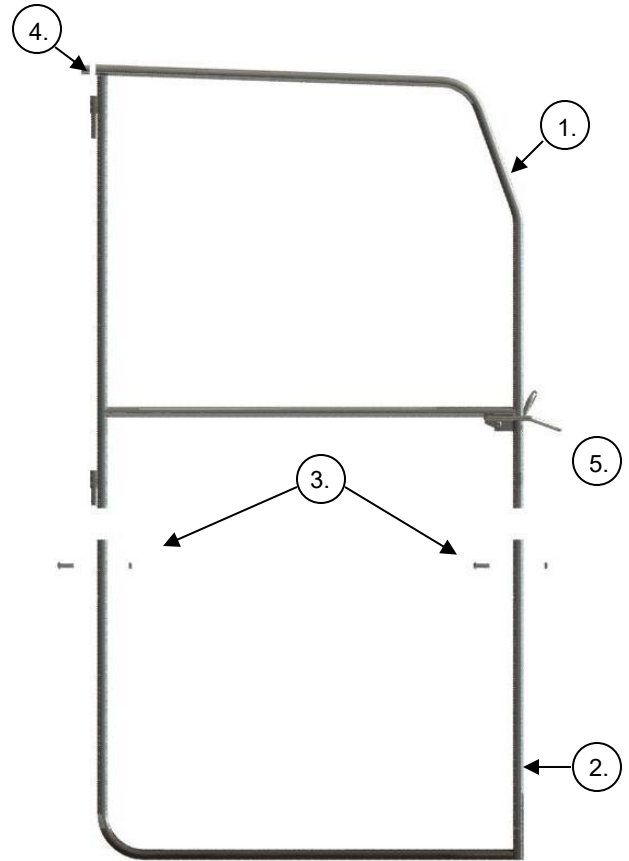

Door Frame Assembly

1. Upper Door Frame
2. Lower Door Frame
3. Pan Head M6 x 25
4. End Plug
5. Handle Assembly

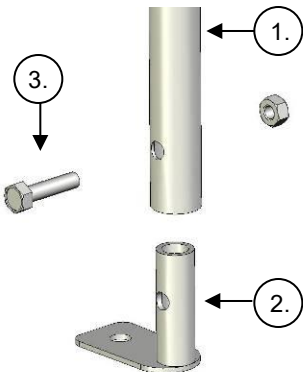

Lower Hangar Frame Assembly

1. Lower Hangar Frame
2. Lower Hangar Mount
3. Pan Head M6 x 25

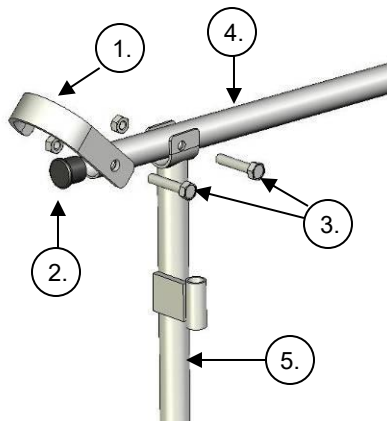

Hook Connector Assembly

1. Hook Connector
2. End Plug
3. Pan Head M6 x 25
4. Upper Door Hangar
5. Rear Hangar Frame

*Orient the hinges on Door Hangar Frame should towards the back of vehicle with barrels facing outwards

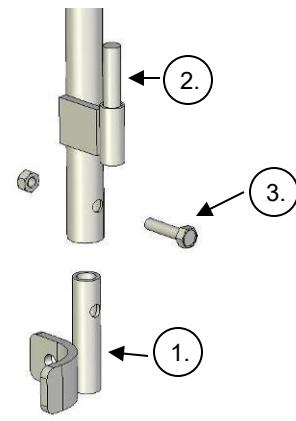

Back Connector Assembly

1. Rear Hangar Mtg. Brkt.
2. Rear Hangar Frame
3. Pan Head M6 x 25

*Do this assembly after the back bottom connector has been attached to Vehicle roll cage. (see step 3-5)

Ranger Doors Installation

Front Hangar Mounting Bracket Installation:

REMOVE ANY EXISTING WINDSHIELD OR TOP BEFORE BEGINNING DOOR INSTALLATION PROCEDURE



1. Place the Bar Clamp 5 inches down from the top of the handle on the passenger side of the Ranger roll cage.



2. Attach the Upper Hangar Mounting Plate to the clamp. The long side of the plate connects to the clamp.

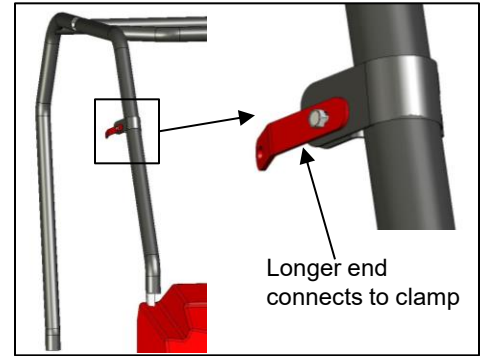

***Note: Flanges should face to the rear & on the outside of the bars**

***Note – Leave bolts loose to adjust clamp & plate position when mounting the Door Hangar Frame Assembly.**



3. Remove the bolts in the lower back portion of the roll cage, save this bolt and nut for the next step.



4. Mount Rear Hangar brkt. using bolt removed in step 3. Orient as shown with hinge barrel facing forwards & to outside.



5. Install the Lower Hangar Mount beneath the lower net block.

Hangar Frame Assembly Mounting Details:

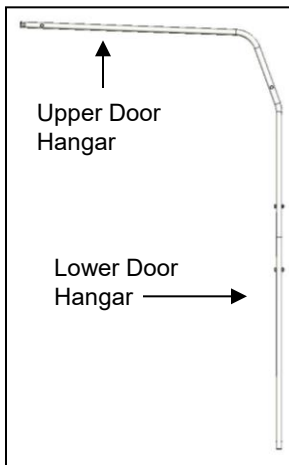

6. Attach lower hangar to upper hangar frame

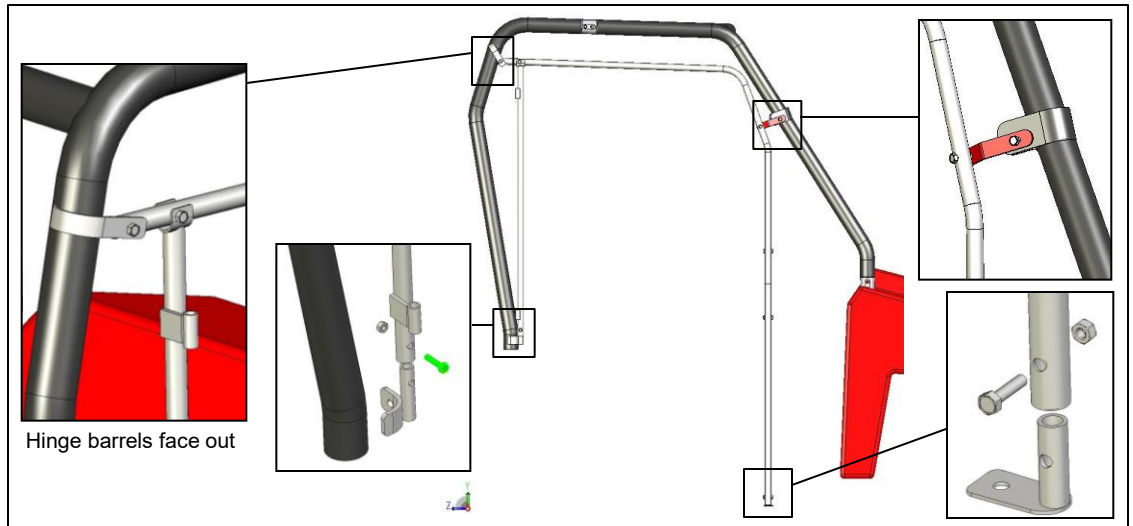

7. Mount the Door Hangar Frame assembly to the vehicle and completely tighten hardware.

Ranger Doors Installation

Textile Installation:

Note: If you have a back panel. Install back panel before door textiles



8. Install the textile side panels over the door hangar frame by wrapping the Velcro flaps around the vehicle's roll cage & the hangar frame assembly.

Tip - Raise the dump bed for easier installation

9. There is a notch in the side doors that make it possible to slide the doors over the Upper Door Hangar Mounting Bracket. Adjust bracket position if required.



11. Pull compression straps over roll cage & buckle. Tug on straps to secure the Side Panels tight.

*** Note: Compression straps route under hard tops**

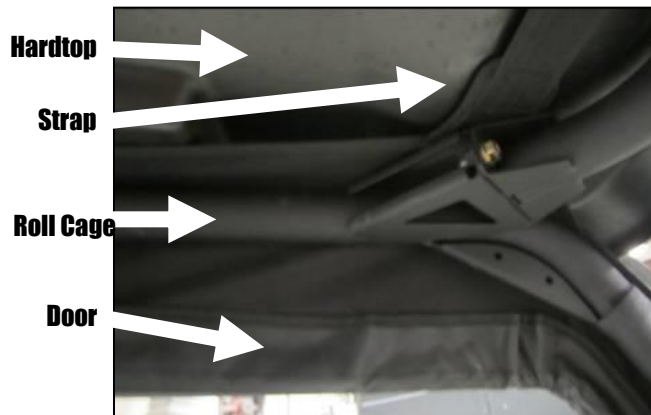

12. When installing doors in conjunction with a hardtop, the straps should go under the hardtop.



13. Buckle the back straps and tighten.



14. Note Velcro inside edges of side panels along roll cage pillars.



15. Wipe roll cage bars with alcohol to remove dirt & grease.

Ranger Doors Installation

Textile Installation:



16. Secure side panels to roll cage bars with Velcro. Adjust position as necessary.

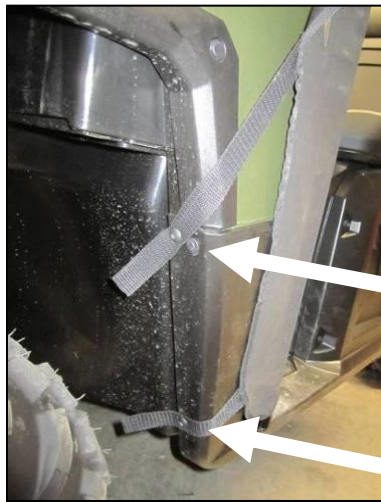

17. The 2 Front Lower Straps on the Side Panels are secured by the 2 Torx bolts that are located in the back edge of the front fender wells.

Pull the straps tight to the bolt locations & mark where the bolts will pass through the strap. Cut a 1/4" hole through the strap for the bolts to pass through.

Remove the 2 Torx bolts in the front fender wells. Pull the Lower Side Panel Straps to the bolt hole locations tight and run the screws through the straps back into their corresponding holes. Ensure that the straps are taut

***Note: Adjust side panel position as required so it fits taugt and with minimal gaping & wrinkles. Tighten down all compression straps once installed.**

Mounting the Doors:



14. Mount the doors by guiding the pins in the back of the door frame onto the hinge barrels along the Rear Hangar Bar.

Accessories Installation:

Installing Windshields with this Door System:

IMPORTANT: Please review the outlined procedure as not all windshield mounting systems are the same & yours may require a different approach to working with this door system.

2 Methods to Mount Windshield with Door System:

Option 1: **PREFERRED METHOD**

Side Panel Pillar Cover under the windshield

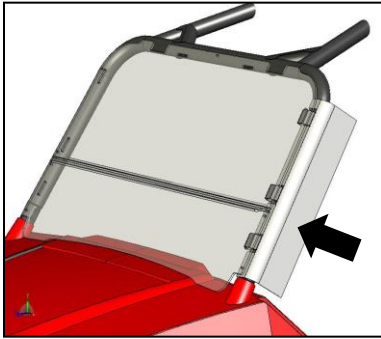

This is preferred method. Best used for 2pc., folding, & 1/2 windshields. Side Panel Velcro's directly to Roll Bar. Notches are cut into side panel to accommodate mounting system. Minimizes interferences with 2pc.

Option 2: **SECONDARY METHOD**

Side Panel Pillar Cover on top of the windshield

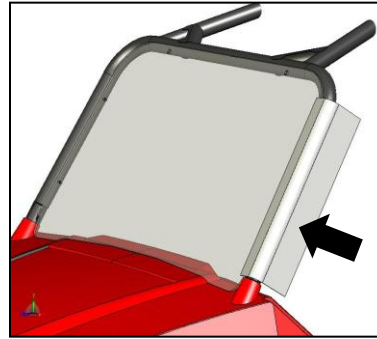

This method is best for full 1pc windshields where user doesn't plan on switching it out after install as Velcro will adhere directly to windshield edge surface. It increases seal slightly but installation is a bit trickier. The surface to adhere the Velcro must be cleaned well, but alcohol should not be applied to acrylic or polycarbonate.

NOTE: Other types of windshields may require different approaches to combining with this door system functions.

Versa-Shield Windshield P/N23048 (not included):

The following procedure is based on Option 1 above. Fully familiarize yourself with the sequence. If you study your windshields mounting procedure, you will be able to retrofit according to your specific requirements.



1. Mount side panel cab sections positioned correctly & tight.

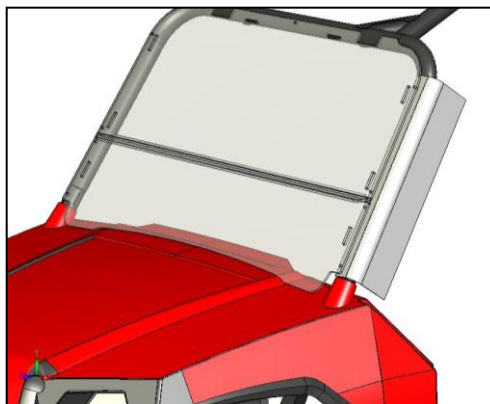

2. Lay the windshield in position noting location of the slots where the mounting straps will go

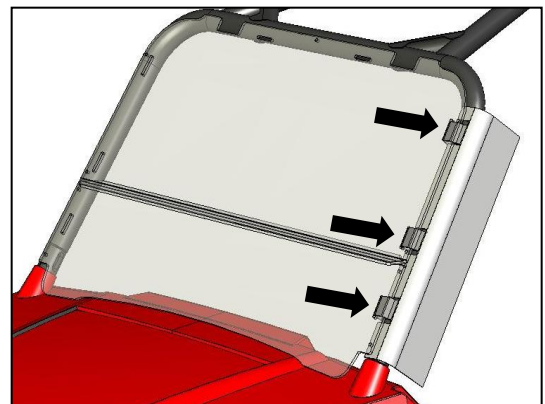

3. Be sure to clearly note where the mounting straps/ clamps will be positioned relative to the side panel

NOTE: You will cut the side panels – Ensure they are positioned correctly.

4. Mark the fabric where straps/ clamps are located as this is where the side panel textile will need to have slots cut.

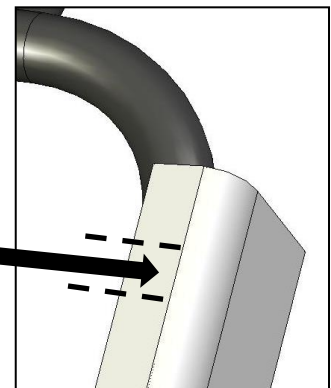
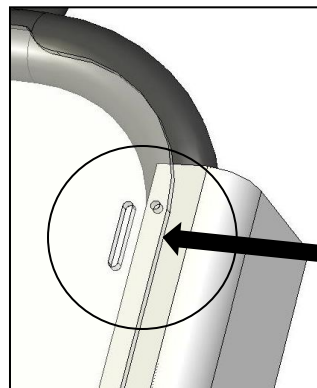

IMPORTANT: Carefully verify the windshield is positioned correctly when marking for the cuts!

Accessories Installation:

Versa-Shield Windshield (not included):



6. Mend the cuts with a lighter. Hold the flame on the material edge just long enough to melt the edge slightly. This will prevent the material fraying over time.

5. Cut 2 horizontal slits across the edge of the fabric to create tabs. Do not cut past the first vertical seam.

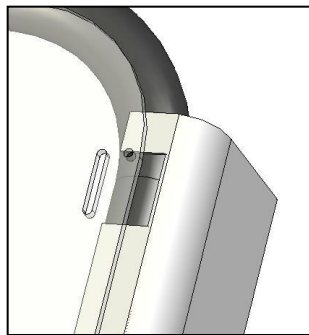

7. Fold cut flap back into panel

6. Install windshield on top of the side panels



8. Install straps lacing through the flap opening to the inside of the cab & secure Velcro strap or P-Clamps. Reference Sezmik Versa-Shield Manual for Strap operation instructions..

SEIZMIK Hood Rack P/N 08052 (not included):



The side panel textile needs to be cut to accommodate the hood rack roll cage clamp / brackets.

Follow the procedure outlined for the windshield strap / clamp and LED Light Bar.

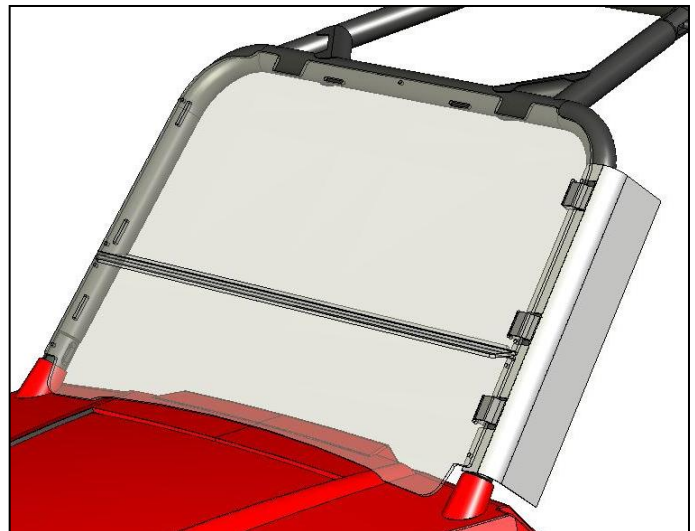

9. Adjust as required & secure straps tightly.

Accessories Installation:

SEIZMIK Side View Mirrors P/N18041 (not included):

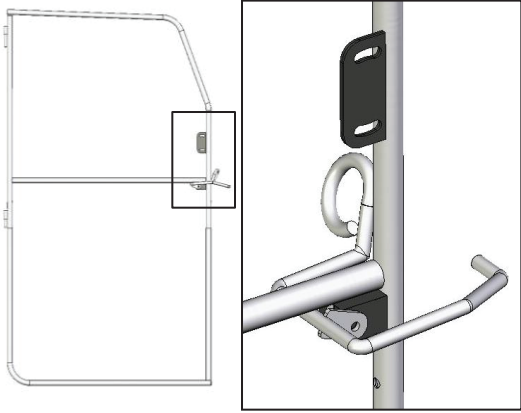

The Upper Door Frame has provisions to mount SEIZMIK 18041 Side View Mirrors.

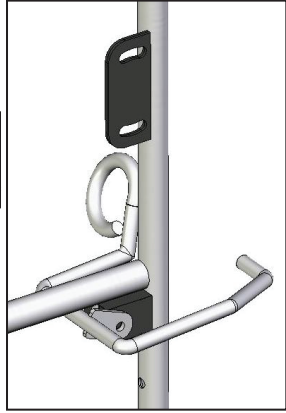

Locate plate behind inside Velcro flap & mark to punch holes in fabric.



Install mirror with supplied hardware. Adjust position as required.

TIP: Tension adjustment bolt to tighten mirror movement if required

SEIZMIK LED Light Bar P/N12030 (not included):



1. Mount bar to vehicle & verify position in front of windshield
NOTE: Verify windshield hardware if applicable



2. Mark position of light bar clamps on roll cage.

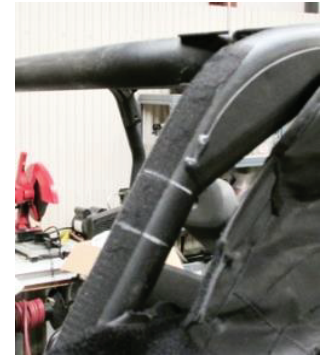

3. Remove bar & Install side panels to the front roll cage bars correctly.
NOTE: Verify position of side panels on the roll cage bars!!! You will cut the material & don't want to cut in the wrong location!!!

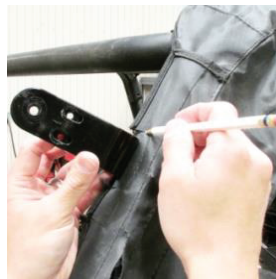

4. Reinstall side panels, verify light bar clamp position & mark fabric



5. Cut fabric across
Do not cut past vertical seam

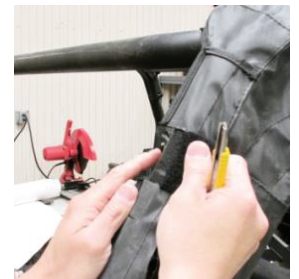

6. Cut fabric across
Do not cut past vertical seam



7. Fold cut flap inside



8. Install light bar bracket & bar

APPENDIX

Full size Polaris Ranger Doors - round tube (06003)		
Item #	Part#	Description
1	54-SW-90345	Upper door frame
2	54-SW-90346	Lower door frame
3	54-SW-90347	Rear hanger frame Driver side
3	54-SW-90348	Rear hanger frame passenger side
4	54-SW-90368	Upper hanger frame
5	54-SW-90349	Lower hanger frame
	54-SW-90350	Lower hanger mount
6	54-SW-90351	Upper hanger mounting plate
8	54-SW-90352	Steel bar clamp
	54-SW-19200	06003 Door HW Kit
9	54-SW-90353	Plastic end plug
10	54-SW-90354	Door handle driver side
10	54-SW-90355	Door handle passenger side
11	54-SW-90673	Plastic spacer
12	54-SW-90357	Hook connector
13	54-SW-90358	Rear hanger mounting bracket
17	54-SW-90359	1/4 - 20 x 2.5" bolt
17	54-SW-90360	1/4 - 20 lock nut
TEXTILES		
1	54-SW-90362	Upper Door Textile passenger side
2	54-SW-90364	lower door textile passenger side
3	54-SW-90361	Upper door textile driver side
4	54-SW-90363	Lower door textile driver side
5	54-SW-90366	Sub frame textile passenger side
6	54-SW-90365	Sub frame textile driver side
	54-SW-90377	1/4" washer
	54-SW-90926	LOWER TEXTILE PASS SIDE 6003A/6005A MOOSE
	54-SW-90927	LOWER TEXTILE DRIVE SIDE 6003A/6005A MOOSE

